

CHUTE FED TRASH COMPACTORS

MODEL XM-40

The XM Series Trash Compactors are bag packers normally installed in below grade trash rooms, used in conjunction with a trash chute system in Hi Rise Apartment Buildings. The units can also be hand fed. The unit typically compacts and extrudes trash into heavy duty trash bags. Single or multiple bags are available. Using the multiple bag system, the unit will compact and extrude up to 500 lbs. of trash before bag removal is required. This system is ideal for times when the machine may be unattended, such as over weekends, etc. Operation is completely automatic, being activated by an electric eye which reacts to the presence of trash in the hopper. The system automatically shuts down when the bag is full.

The XM Series consists of the Model XM-40 and the XM-40M. The Model XM-40 is the full-size machine, while the XM-40M is slightly shorter for applications where a standard length machine will not fit. Both machines are equipped with an electrically interlocked hopper door, located on the hopper front, for service access.



MODEL SELECTION

There are two standard models in the series:

- **Model XM-40** - the full-size trash compactor equipped with an electrically interlocked hopper door, located on the hopper front, for service access.
- **Model XM-40M** - slightly shorter trash compactor for applications where a standard length machine will not fit. Is also equipped with an electrically interlocked hopper door, located on the hopper front, for service access.

FEATURES

The XM Series Trash Compactors are extremely practical, low-priced, single or multi-bag compactors. A photoelectric sensor starts the compaction cycle when refuse enters the hopper and turns the machine off when the hopper is empty. The compactor automatically shuts off to prevent damage from an oversized or uncrushable object. A service access door is provided on the front of the hopper, equipped with an electrically interlocked safety switch which prevents the machine from operating if the access door is open.

SPECIFICATIONS

	XM-40	XM-40M
Chamber Capacity	3.3 cf	2.7 cf
Compaction Force (M)	38,000 lbs	38,000 lbs
Ram Face Pressure (M)	165 psi	210 psi
Volume Displacement	8.6 cy/hr	10.0 cy/hr
Cycle Time	45 seconds	35 seconds
Overall Dimensions (L x W x H)	80 x 29 x 70 in	71 x 29 x 64 in
Weight, without container	1,500 lbs	1,400 lbs
Container Type	Single/Multiple Bag	Single/Multiple Bag
Motor Power, AC, 60 Hz	208/220/440V, 3 phase, 4 wire	208/220/440V, 3 phase, 4 wire
Motor Horsepower	5 HP	5 HP

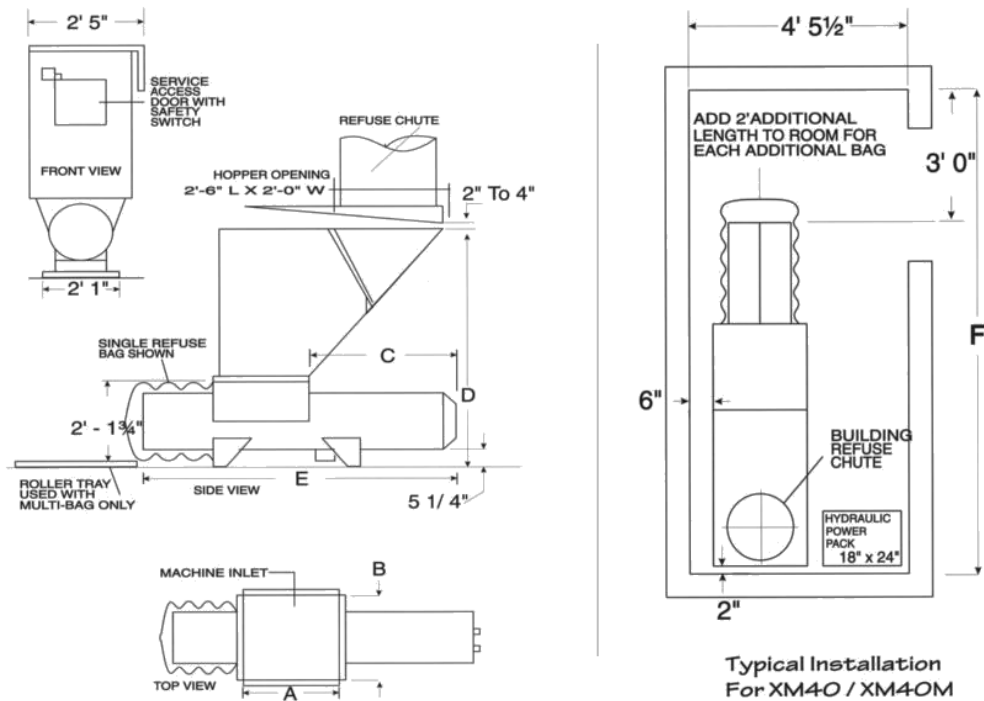

DIMENSIONS

	A	B	C	D	E	F
XM-40	2' - 0"	2' - 0"	3' - 0"	5' - 10 1/4"	6' - 8"	10' - 3 1/2"
XM-40M	1' - 9"	2' - 0"	2' - 7 1/2"	5' - 3 3/4"	5' - 10 1/2"	9' - 5"