

CHUTE FED COMPACTORS MODEL CA-.5 WITH SINGLE CYLINDER

This compactor is designed to pack into a 2 or 3 yard front load or rear load container where overall space utilization is critical.

These powerful units are the perfect solution for high-rise apartments, hotels, hospitals and office buildings or anywhere space is very limited.

FEATURES

- UL/CUL listed control panel
- Single side latching for easy and quick container removal
- ANSI Z245.21 compliant
- Quiet operating vane pump
- Key operated controls
- Can be equipped with high-rise chute hoppers, ground feed hoppers and any other special installation solution requirement
- Space saver design
- Special modifications quoted upon request
- Rugged construction provides long life
- Compactions ratios average 4 to 1, depending on material
- Excellent compaction of dry and/or wet material
- Ideal for apartment buildings, hotels, retail shops or anywhere space is limited

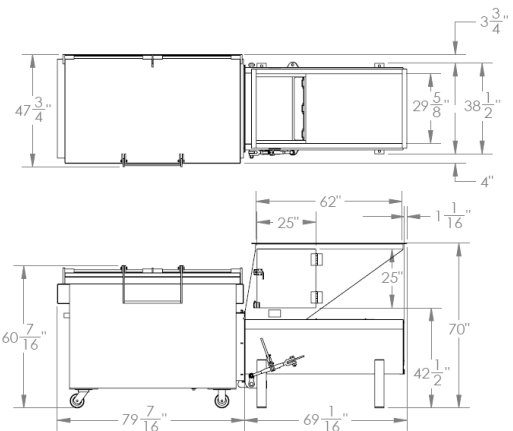
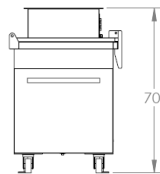

SPECIFICATIONS

Dimensions WxDxH (inches): 40 x 72 x 42	Ram Penetration (inches): 5.5
Clear Top Opening (inches): 27 W x 20 D	Ram Face Dimensions (inches): 29.75 W x 18 H
Load Height (inches): 37.5	Operating Pressure (psi): 1,100-1,400
Power Supply: 208-230/460 VAC 60 Hz Three Phase	Weight (lbs): 1,840 with hopper
Motor (HP): 3	Cycle Time Average (seconds): 38
Ram Force (lbs): 13,800-17,500	

Due to continual product improvement Compactors Inc. reserves the right to change specifications without notice. The information and pictures used in the document are for illustrative purposes only.