

## WASTECADDY HD DUMPSTER MOVER

Moves dumpsters up to 10,000 lb on a level surface. Will move loads up steep inclines such as parking garage ramps.

### BENEFITS

- **Safety** - The trash room is the #1 area for injuries in a multi-family property
- **Efficiency** - The WasteCaddy can double the efficiency in the trash room.
- **Lower Risk** - Reduce Workers Comp insurance premiums and lower your E-MOD rating.



### FEATURES

- 36 volt electrical system incorporating three 105 amp batteries
- On-board 4.5 amp automatic charger
- Charge from 20 amp 120 v AC outlet
- Battery discharge indicator
- Emergency stop button
- Capacity – 10,000 lb dumpster on level surface
- Speed – 0 to 3 mph, forward / reverse
- Foam-filled non-marking tires
- Brakes hold load when parked on incline

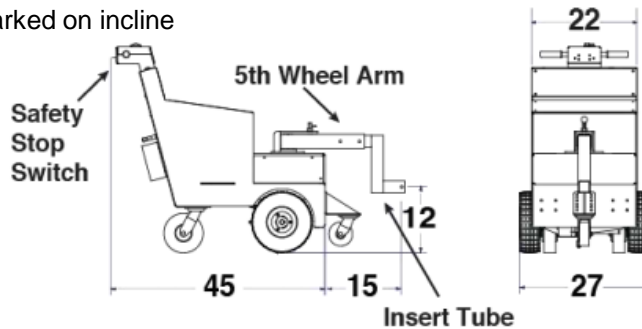

### WasteCaddy



### OPTIONS

Safety Horn	Maintenance Free Batteries
Flashing Light and Pole	15 Amp Weatherproof Charger
Upgrade to Snow Tires for Snow and Ice	Dumpster Receiver
Stop Safety Switch	

Due to continual product improvement Compactors Inc. reserves the right to change specifications without notice. The information and pictures used in the document are for illustrative purposes only.