

WASTECADDY STANDARD DUMPSTER MOVER

Moves dumpsters that would normally require 2-3 personnel. Up to 5000 lb capacity on a level surface. Moderate to steep inclines.

BENEFITS

- **Safety** - The trash room is the #1 area for injuries in a multi-family property
- **Efficiency** - The WasteCaddy can double the efficiency in the trash room.
- **Lower Risk** - Reduce Workers Comp insurance premiums and lower your E-MOD rating.



FEATURES

- 36 volt electrical system incorporating three 105 amp batteries
- On-board 4.5 amp automatic charger
- Charge from 20 amp 120 v AC outlet
- Battery discharge indicator
- Emergency stop button
- Capacity – 5000 lb dumpster on level surface
- Speed – 0 to 3 mph, forward / reverse
- Foam-filled non-marking tires
- Brakes hold load when parked on incline

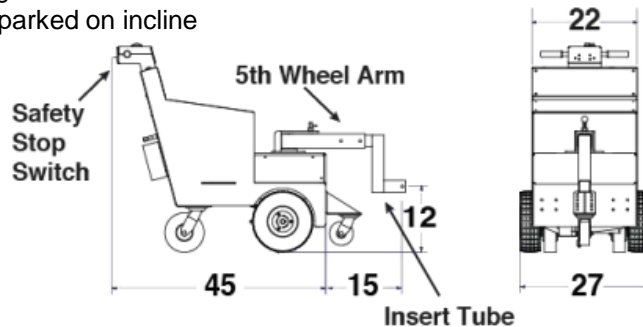

WasteCaddy



OPTIONS

Safety Horn
Flashing Light and Pole
Upgrade to Snow Tires for Snow and Ice
Stop Safety Switch

Maintenance Free Batteries
15 Amp Weatherproof Charger
Dumpster Receiver

Due to continual product improvement Compactors Inc. reserves the right to change specifications without notice. The information and pictures used in the document are for illustrative purposes only.