

# HEAVY DUTY GRANULATORS

## B SERIES

Cumberland Heavy Duty Granulators are designed for the most demanding applications. From low density fiber to heavy purgings, Cumberland's largest granulators are ready to tackle your high-capacity size reduction needs. With a broad range of models and options, the Heavy Duty Series Granulators are designed with large throughput processes in mind. The toughest granulators on the market are ready to take on your toughest applications.

- High shear rotor design maximizes every cut
- Precision machined internal surfaces maximize material flow
- Outboard mounted bearings reduce contamination risk and support maintenance
- Multiple safety features built in every unit

### Typical Applications

- Large scale processing of the hardest materials in the most challenging shapes
- Tire recycling
- Cast blocks and purgings, including ABS
- Nylon, polypropylene, polycarbonate, acetate, and many more



## SPECIFICATIONS

	37B	50B
Dimensions (W x L x H)	135" x 46" x 127"	140" x 46" x 164"
Weight	11,000 lbs	15,000 lbs
Cutting Chamber	18" x 37"	20" x 50"
Throughput	2,500 lbs/hr	3,500 lbs/hr
Standard Motor	100 HP	150 HP
Infeed Height	104"	112"

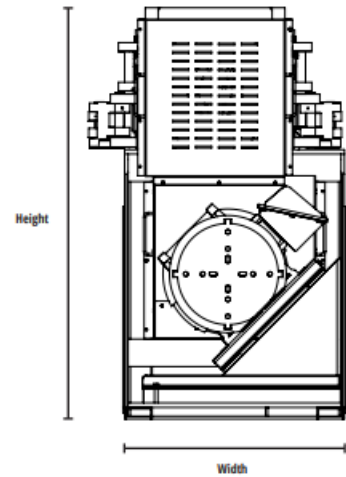
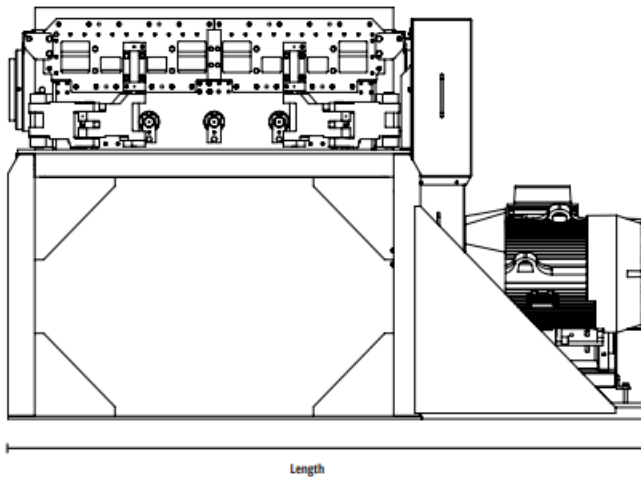

Due to continual product improvement Compactors Inc. reserves the right to change specifications without notice. The information & pictures used in the document are for illustrative purposes only. Compactors Inc. equipment is ETL/CSA certified with UL listed controls & meets or exceeds ANSI standard Z245.5.