

VERTICAL BALER

MODEL V74XHD

Our standard V74XHD (heavy duty) features a 10 HP High Efficiency Power Unit. Offering a 72" wide feed opening and a 40" deep chamber, this unit is perfect for white-goods boxes for which penetration is required. It has a 60" stroke cylinder and begins compaction closer to the bottom of the chamber for more lbs. per cubic foot and less material spring-back.

Ideal for: • Grocery Stores • Home Retailers • Pharmacies • Big Box Retailers • National Accounts • Commissaries • Warehouses • Distribution Centers • Hospitals, Schools & Universities • Recyclers

PERFORMANCE

- **Nominal Bale Size** – 72" x 40" x 48"
- **Bale Weight** – Up to 1700 lbs. OCC
- **Bale Volume** – 80 cu. ft.
- **Number of Bale Tie Slots** – 7
- **Compact Force lbs** – 84,667
- **Platen Pressure** – 30 PSI
- **Average Cycle Time** – 57 Seconds
- **Loading Height** – 49.5"
- **Ejector System** – Semi-Automatic



HYDRAULIC/ELECTRICAL

- **Motor HP** – 10
- **Voltage 3 Phase** – 208, 230, 480
- **Full Load Amps** – 32A, 28A, 14A
- **Pump GPM** – 12/4 HiLo
- **Normal System Pressure PSI** – 2200
- **Cylinder Bore** – 7" x 60"
- **Hydraulic Tank-Capacity Gallons** - 40

AVAILABLE OPTIONS

- Slotted Front Door
- Wire Guides (allows for front bale tie-off)
- Rear Feed Opening, Front Eject
- Feed Chute
- Counter Weighted Floppy Retainer Dogs
- Oil Heater
- Weather Proof Package

DIM. (in./mm)

- A. 49.5/1257
- B. 102/2590
- C. 53.5/1359
- D. 156.5/3975
- E. 114/2908

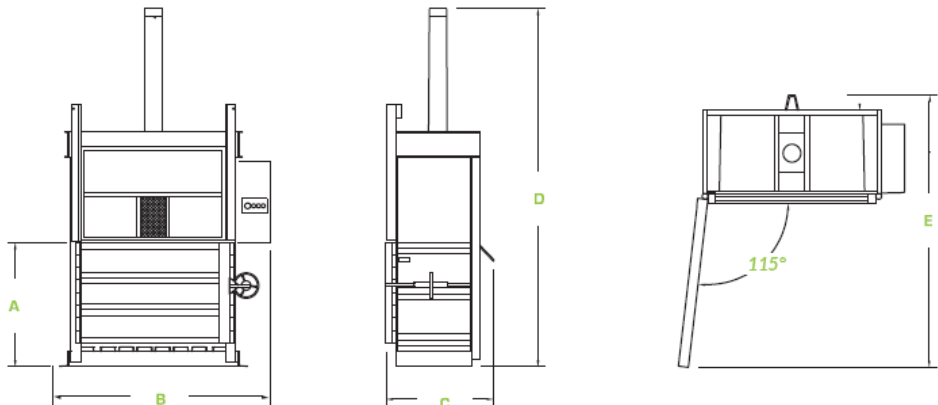

Due to continual product improvement Compactors Inc. reserves the right to change specifications without notice. The information and pictures used in the document are for illustrative purposes only. Compactors Inc. equipment is ETL/CSA certified with UL listed controls and meets or exceeds ANSI standard Z245.5.