

CLOTHING VERTICAL BALER – MODEL V63HD-CM

The V63HD-CM Clothing Baler is uniquely designed to produce up to a 1,300lb bale of clothing. This baler comes standard with an Extra Heavy Duty Frame and Floppy Dogs.

PERFORMANCE

- **Nominal Bale Size** - 30" x 48" x 60"
- **Bale Weight** - Up to 1300 lbs
- **Bale Volume** - 50 cu. ft.
- **No. of Bale Tie Slots** - 5
- **Compact Force lbs.** - 67,857
- **Platen Pressure** - 38 PSI
- **Average Cycle Time** - 48 Seconds
- **Loading Height** – 54.50"
- **Ejector System** - Semi-Automatic
- **Full Bale Light** - Standard

SPECIFICATIONS

- **Motor HP** - 10
- **Voltage 3 Phase (V = Volts)** - 208V, 230V, 480V
- **Full Load Amps (A = Amps)** - 32A, 28A, 14A
- **Pump GPM** – 12.3
- **Factory Set System Pressure PSI** - 2400
- **Cylinder Bore x Stroke** - 6" x 48"
- **Hydraulic Tank-Capacity Gallons** - 22

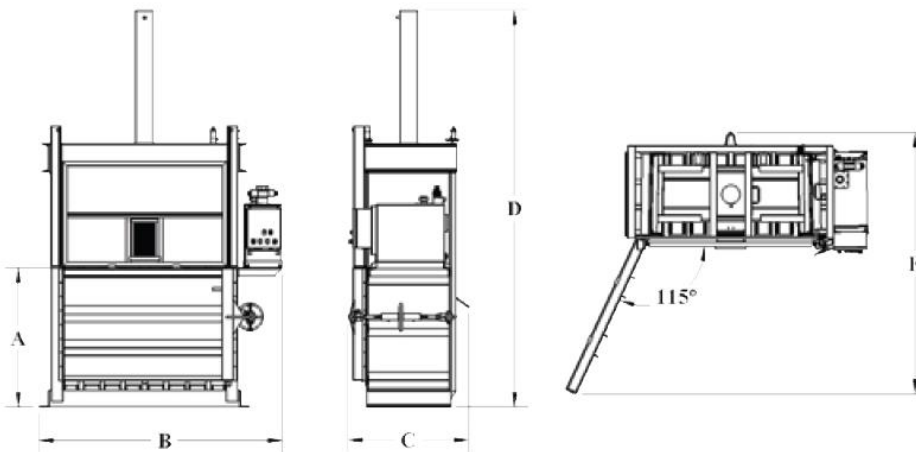

Dimensions (inches/mm)

A – 54.5/1384

B – 88.7/2254

C – 45.5/1154

D – 145.1/3686

E - 97.7/2481

Due to continual product improvement Compactors Inc. reserves the right to change specifications without notice. The information and pictures used in the document are for illustrative purposes only.