

GAYLORD ROTATOR BOXES

These rotating containers help in the process of emptying the content inside of your cardboard corrugated (Gaylord) boxes.

FEATURES

- Empties the content inside of your cardboard corrugated (Gaylord) boxes.
- Wide range of flexibility in corrugated box sizes with our exclusive adjustable containing arms.
- Preserves the longevity of your corrugated cardboard boxes with this safe and efficient material handling process.
- Options: Cross member round reinforced pipe. Wider adjustable side rails. Other color options.

Finish – Roura Green Paint Standard Color

Options – Cross member round reinforced pipe. Wider adjustable side rails. Other color options.

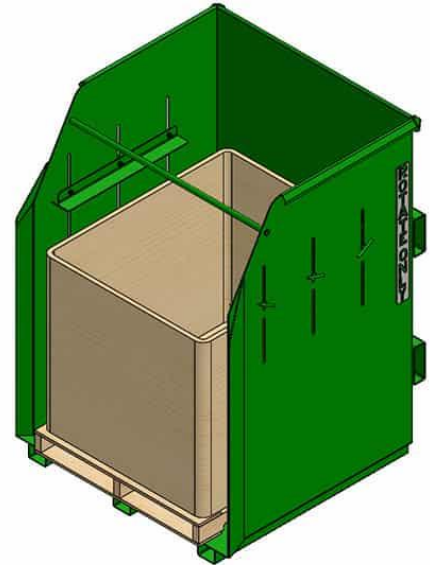

MODEL RANGES

MODEL #	WEIGHT	INSIDE WIDTH	DIMENSIONS
RGR4871-10G	705 lbs	47"	51" x 50 1/2" x 71 1/2"
RGR4871-7G	890 lbs	47"	51" x 50 1/2" x 71 1/2"

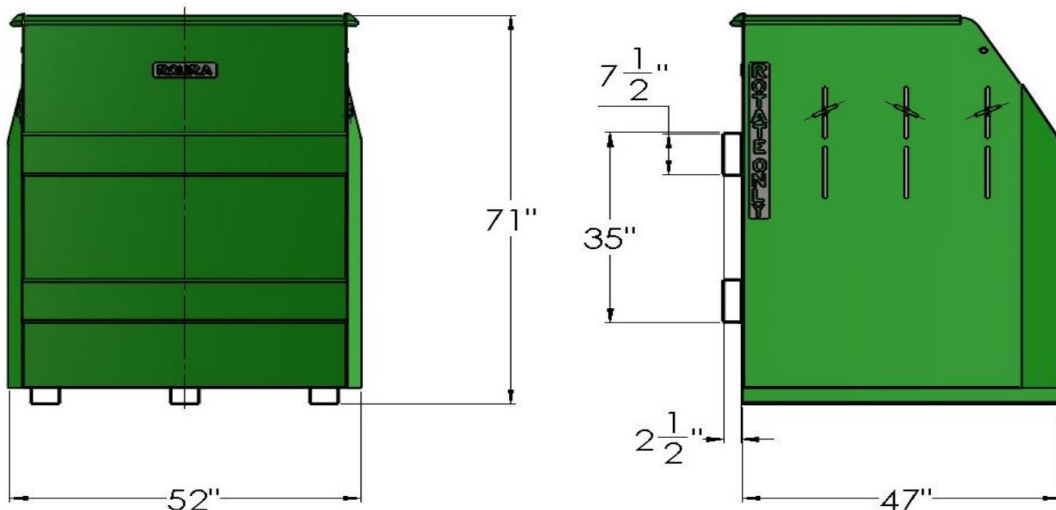

Due to continual product improvement Compactors Inc. reserves the right to change specifications without notice. The information and pictures used in the document are for illustrative purposes only.