

VERTICAL BALER MODEL B20

The B20 is a versatile machine that is suitable for many different industries, including big-box stores, small retail shops, and manufacturing facilities.

- Low noise level (<62 dB)
- Quickly tie off bales
- Impressive throughput
- Short press cycle
- Install against wall with front placed strapping
- Large compression ratio



FEATURES

VERSATILE MACHINE FOR VARIOUS INDUSTRIES

This machine allows you to recycle a variety of materials in a number of different industries.

OPTIMAL BALE SIZE

Finished bales are the optimal size. They fit on a standard US pallet and can be transported easily.

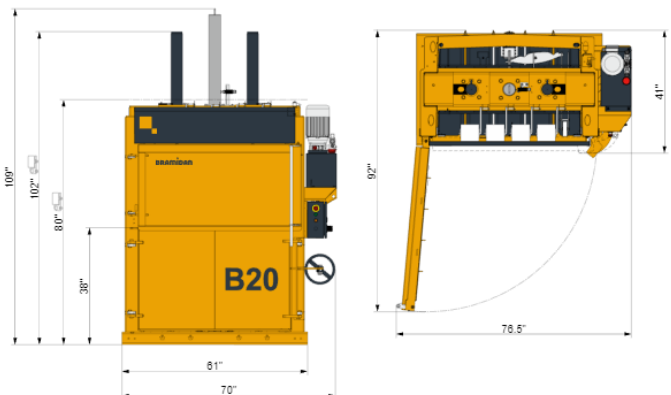

SPECIFICATIONS

Bale Weight Cardboard (lbs): 450-550

Bale Weight Plastic Foil (lbs): 550-650

Bale Size WxDxH (inches): 48 x 30 x 30

Power Supply: 208/230/480V 3-Phase 60 Hz

Motor (HP): 5.5

Noise Level (dB): 62-64

Cycle Time Average (seconds): 37

Press Force: 44,100 lbs

Dimensions WxDxH (inches): 70 x 41 x 109 / 80

Machine Weight (lbs): 2,750

Feed Opening WxH (inches): 48 x 22

Full Bale Light: Yes

Bale Eject: Automatic

Stroke (inches): 30

Number of Ties: 4

Type of Tying: Twine

Due to continual product improvement Compactors Inc. reserves the right to change specifications without notice. The information and pictures used in the document are for illustrative purposes only.