

VERTICAL BALER MODEL B4

With 8,800 lbs. of press force, a deep stroke, and efficient retainer dogs, the B4 is a dynamic machine that has many more features than the standard small footprint baler.

- Automatic ejection system
- Full bale indicator light
- Very low noise level (<60 dB)
- Low overall height (6.5 ft.) and small base area (3 ft.)
- Finished bales weigh 85 - 155 lbs.
- Easy and convenient operation in front of baler



FEATURES

POWERFUL AND COMPACT

The B4 is a small machine that packs a powerful punch with a high press force and an automatic ejection system.

SAFE TO OPERATE

Users safely eject finished bales using the two-hand ejection system.

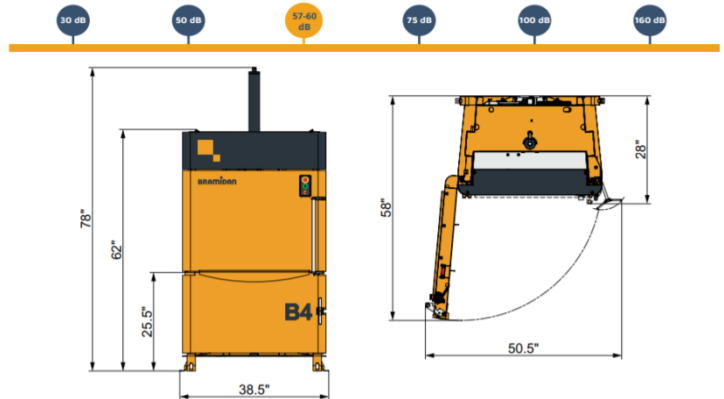

SPECIFICATIONS

Bale Weight Cardboard (lbs): 85-130
Bale Weight Plastic Foil (lbs): 110-155
Bale Size WxDxH (inches): 30 x 20 x 24
Power Supply: 110V 1-Phase 60Hz 10A
Motor (HP): 1
Noise Level (dB): 57-60
Cycle Time Average (seconds): 48
Type of Tying: Twine

Dimensions WxDxH (inches): 39 x 28 x 78
Machine Weight (lbs): 661
Feed Opening WxH (inches): 30 x 18
Full Bale Light: Yes
Bale Eject: Automatic
Stroke (inches): 26
Number of Ties: 2
Press Force: 8,800 lbs

Due to continual product improvement Compactors Inc. reserves the right to change specifications without notice. The information and pictures used in the document are for illustrative purposes only.