

DRUM CRUSHER MODEL DP16

The drum press DP16 is designed for compression of oil drums and other drums without explosive contents. It is suitable for drums up to 55 gallons.

- Up to 90% compaction
- Spikes in the press plate puncture the drum and remove air
- High degree of safety
- Interlock system prevents the motor from running unless the door is closed
- Compressed drums are easy to stack and store



FEATURES

COMPRESS DRUMS BY 90%

Easily compress your steel or oil drums. The drum press compacts the drums by 90%.

FOR DRUMS UP TO 55 GALLONS

The drum press easily handles drums without explosive content up to 55 gallons.

AVAILABLE OPTION

DRIP TRAY FOR RESIDUALS

We offer a special drip tray to collect residuals

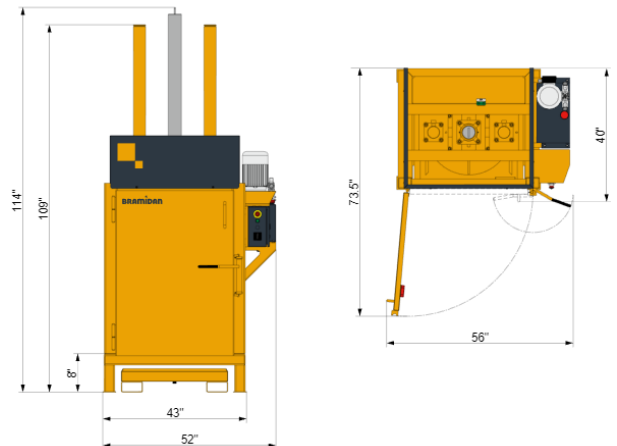

SPECIFICATIONS

Press Force (lbs): 35,200

Power Supply: 3x 208/230/480V 60Hz

Motor (HP): 5.5

Noise Level (dB): 70-75

Cycle Time Average (seconds): 30

Dimensions WxDxH (inches): 52 x 40 x 114

Machine Weight (lbs): 1,411

Feed Opening WxH (inches): 24 x 37

Load Height (inches): 8

Stroke (inches): 39

Due to continual product improvement Compactors Inc. reserves the right to change specifications without notice. The information and pictures used in the document are for illustrative purposes only.