

VERTICAL BALER

MODEL V6342

One of our most popular machines, this 60" Vertical Downstroke Baler is ideally suited for OCC & shrink-wrap, producing bales up to 1,000 lbs.

IDEAL FOR

- Big Box Retailers
- Commissaries
- Distribution Centers
- Grocery Stores
- Home Retailers
- Hospitals
- National Accounts
- Pharmacies
- Recyclers
- Schools
- Universities
- Warehouses



PERFORMANCE

Nominal Bale Size	60" x 30" x 48"
Bale Weight	Up to 1000 lbs OCC
Bale Volume	50 cu. Ft.
No. of Bale Tie Slots	5
Compact Force Lbs – Normal/Max	56,548/62,172
Platen Pressure	32 PSI
Average Cycle Time	49 Seconds
Loading Height	59.5"
Ejector System	Semi-Automatic

HYDRAULIC/ELECTRICAL

Motor HP	10
Voltage 3 Phase	208V, 230V, 480V
Full Load Amps	30A, 28A, 14A
Pump GPM	10.5
Normal/Max System Pressure PSI	2000/2200
Cylinder Bore x Stroke	6" x 42"
Hydraulic Tank-Capacity Gallons	22

DIMENSIONS (in/mm)

- A. 54.5/1384
- B. 87/2210
- C. 45.5/1154
- D. 135/3429
- E. 97/2481

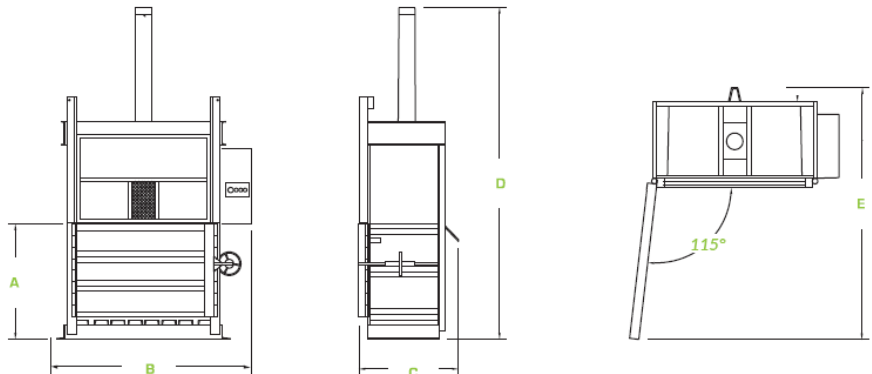

Due to continual product improvement Compactors Inc. reserves the right to change specifications without notice. The information and pictures used in the document are for illustrative purposes only. Compactors Inc. equipment is ETL/CSA certified with UL listed controls and meets or exceeds ANSI standard Z245.5.