

## VERTICAL BALER MODEL V730CC

This unit is 72" wide to accommodate larger or more lengthy boxes. This unit is ideal for appliance or television boxes and other larger cardboard cartons.

### IDEAL FOR

- Big Box Retailers
- Commissaries
- Distribution Centers
- Grocery Stores
- Home Retailers
- Hospitals
- National Accounts
- Pharmacies
- Recyclers
- Schools
- Universities
- Warehouses



### PERFORMANCE

Nominal Bale Size	72" x 30" x 48"
Bale Weight	Up to 1300 lbs OCC
Bale Volume	60 cu. Ft.
No. of Bale Tie Slots	7
Compact Force Lbs – Normal/Max	56,548/62,172
Platen Pressure	27 PSI
Average Cycle Time	49 Seconds
Loading Height	49.5"
Ejector System	Semi-Automatic

### HYDRAULIC/ELECTRICAL

Motor HP	10
Voltage 3 Phase	208V, 230V, 480V
Full Load Amps	32A, 28A, 14A
Pump GPM	10.5
Normal/Max System Pressure PSI	2000/2200
Cylinder Bore x Stroke	6" x 42"
Hydraulic Tank-Capacity Gallons	22

### DIMENSIONS (in/mm)

- A. 49.5/1257
- B. 99/2515
- C. 45.5/1154
- D. 135/3429
- E. 110/2794

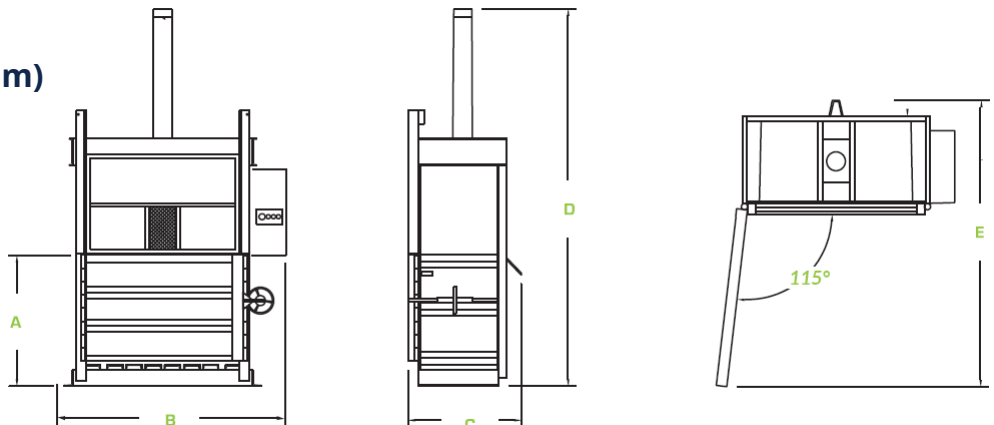

Due to continual product improvement Compactors Inc. reserves the right to change specifications without notice. The information and pictures used in the document are for illustrative purposes only. Compactors Inc. equipment is ETL/CSA certified with UL listed controls and meets or exceeds ANSI standard Z245.5.