

BDS BOTTLE DISINTEGRATION SYSTEM

The BDS Bottle Disintegration System reduces the volume of glass bottle waste by as much as 85%, lowering your disposal fees and paying for itself over time. The BDS unit is easy to use and crushes a bottle in mere seconds, while being no louder than a standard blender.

- Reduces volume of glass bottle waste by as much as 85%
- Disintegrates beer, wine & liquor bottles up to 4" in diameter & 14" in height
- The 4-gallon bucket holds approximately 43 lbs when full and is accessible for emptying by opening the front door
- Compact design fits easily under the bar or in a service station
- It takes seconds to crush a bottle and is no louder than a standard blender
- Stainless steel interior & exterior resists corrosion & is easy to keep clean
- Includes safety interlock switches to ensure safe operation
- The unit shuts down and a red indicator light is illuminated if the front access door is open or the bucket is not in place
- Multi-level baffle system on feed chute and gasket seal to maximize glass containment
- No empties means more stock space and a cleaner environment
- Green indicator light identifies when unit is running
- Easy operation - simply turn it on and push a bottle down the feed chute
- Includes locking casters so unit can be easily moved for cleaning
- Weighs 142 lbs. Shipping weight is 167 lbs.
- Includes two buckets. Additional buckets may be ordered under accessory part number 14000053



Multi-level baffle system on feed chute for safe operation and glass containment

Disintegrates beer, wine, and liquor bottles up to 4" in diameter and 14" in height



120V operation. Grounded cord and plug provided. Available for export with 220V/50Hz electrical.

Stainless steel interior and exterior resists corrosion and is easy to keep clean

The compact design fits easily under a bar or in a service station



Includes locking casters so unit can be easily moved for cleaning



Easy operation - simply turn it on and push a bottle down the feed chute. Green indicator light illuminates when unit is running. Red indicator light illuminates when a fault has occurred.



Closed door safety sensor prevents operation when front door is open



Bucket stop bar ensures bucket is fully seated when door is closed

Includes safety interlock switches



Bucket seating safety sensor prevents operation when the bucket is not in place



Bucket shown cut away for illustrative purposes



UP TO
85%
VOLUME
REDUCTION

The 4-gallon bucket weighs approximately 43 pounds and holds approximately 4 cases of disintegrated long neck beer bottles when full



Intertek
4004503
Certified to ANSI/UL STD 73
C22.2 No. 98

Due to continual product improvement Compactors Inc. reserves the right to change specifications without notice. The information and pictures used in the document are for illustrative purposes only.

BDS BOTTLE DISINTEGRATION SYSTEM

SPECIFICATIONS

Electrical	Materials
120V, Single phase, 60Hz, 9-foot NEMA 5-15P grounded cord included	20 gauge stainless steel parts include: cabinet, covers
Dedicated 15 amp circuit recommended	14 gauge stainless steel parts include: drum, shelf
Power requirements - 9.0 amps	1/4" steel plate: motor mount
Also available for export with 220V/50Hz or 220V/60Hz electrical. Specify accessory number CE-BDS.	Hardened steel: crusher bar
	Structural pipe, SCH 40: bottle chute

Capacity
The 4-gallon bucket weighs approximately 43 pounds and holds approximately 4 cases of disintegrated long neck beer bottles when full

Service Access
Top cover, front top panel, and door must remain accessible for service
One-half inch of clearance above top is required for proper air flow

The BDS includes two buckets. Additional buckets may be ordered under accessory part number 14000053.

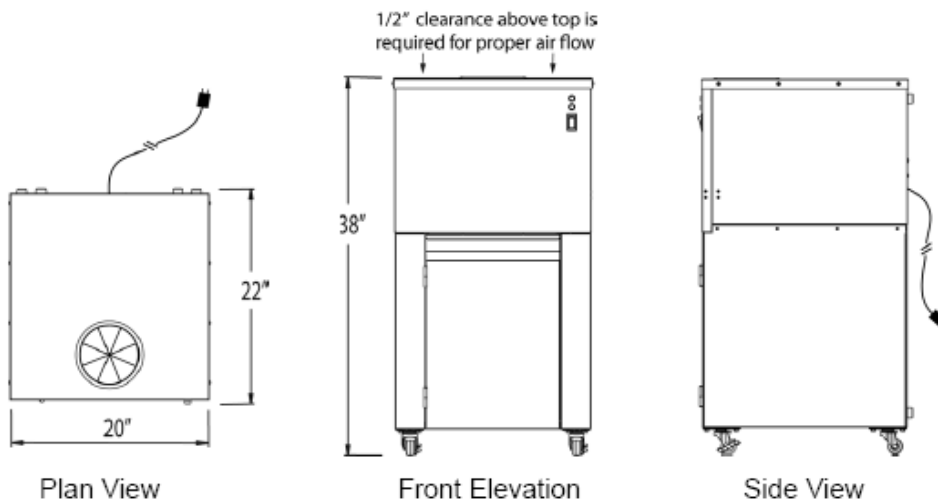

Due to continual product improvement Compactors Inc. reserves the right to change specifications without notice. The information and pictures used in the document are for illustrative purposes only.