

## VERTICAL BALER

### MODEL V43OCC

**“The Perfect Cardboard Baling Solution for Facilities with Space Constraints. 10HP Motor. Bale Weights Up To 700 Pounds.”**

The Model V43OCC is designed to produce high density bales while taking up minimal space. This model comes standard with a full bale switch and is ideal for Retailers, Grocery Stores, Drug Stores, Distribution Centers and other organizations and have space constraints.

## PERFORMANCE

- **Nominal Bale Size** – 48" x 30" x 48"
- **Bale Weight** – Up to 700 lbs. OCC
- **Bale Volume** – 40 cu. ft.
- **Number of Bale Tie Slots** – 4
- **Compact Force lbs. – Normal/Maximum** – 56,548/62,202
- **Platen Pressure** – 40 PSI
- **Average Cycle Time** – 48 Seconds
- **Loading Height** – 49.5"
- **Ejector System** – Semi-Automatic



## HYDRAULIC/ELECTRICAL

- **Motor HP** – 10
- **Voltage 3 Phase** – 208, 230, 480
- **Pump GPM** – 10.5
- **Normal System Pressure PSI** – 2000
- **Maximum System Pressure PSI** – 2200
- **Cylinder Bore** – 6"
- **Hydraulic Tank-Capacity Gallons** - 22

## AVAILABLE OPTIONS

- Slotted Front Door
- Wire Guides (allows for front bale tie-off)
- Rear Feed Opening, Front Eject
- Feed Chute
- Counter Weighted Floppy Retainer Dogs
- Oil Heater
- Weather Proof Package
- Full Bale Light

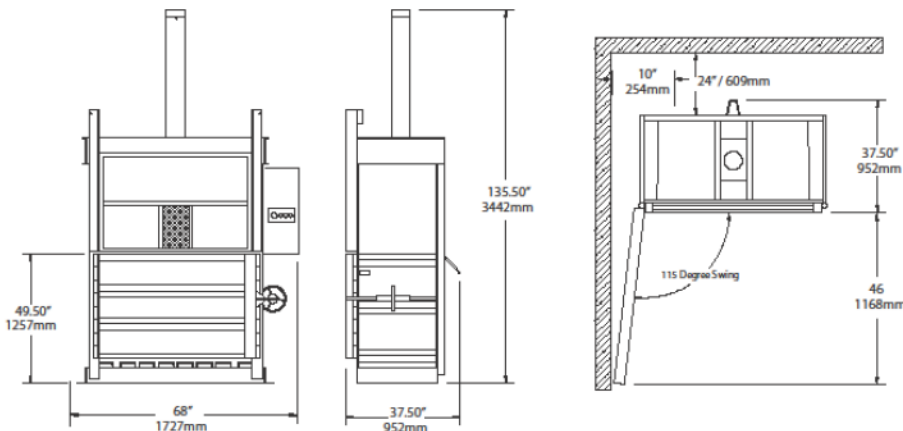

Due to continual product improvement Compactors Inc. reserves the right to change specifications without notice. The information and pictures used in the document are for illustrative purposes only. Compactors Inc. equipment is ETL/CSA certified with UL listed controls and meets or exceeds ANSI standard Z245.5.