

VERTICAL BALER MODEL X10 HD

The X10 HD is low-profile baler that is perfect for locations with a limited amount of space.

- Efficient and compact
- Low overall height (75 in.) with internal cross cylinders
- Fast cycle time
- Press force of 22,000 lbs.
- Small footprint (52 x 41 x 75 in.)
- Durable compaction
- Available in both single-phase and three-phase power packs
- Safely open lower door with turnbuckle



FEATURES

POWERFUL PRESS FORCE

The X10 HD is a small and compact machine with a powerful press force that's unique for its size.

SAFE EJECTION PROCESS

The ergonomic two-hand ejection sequence safely ejects the finished bale and eliminates risk for injury.

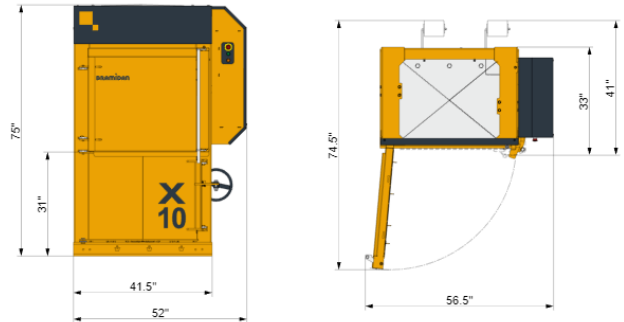

SPECIFICATIONS

Bale Weight Cardboard (lbs): 150-200

Bale Weight Plastic Foil (lbs): 175-245

Bale Size WxDxH (inches): 30 x 24 x 24

Power Supply: 110V 1-Phase 60Hz 20A

Motor (HP): 2

Noise Level (dB): 62-64

Cycle Time Average (seconds): 45

Type of Tying: Twine

Dimensions WxDxH (inches): 52 x 41 x 75

Machine Weight (lbs): 1,470

Feed Opening WxH (inches): 31 x 24

Full Bale Light: Yes

Bale Eject: Automatic

Stroke (inches): 33

Number of Ties: 3

Due to continual product improvement Compactors Inc. reserves the right to change specifications without notice. The information and pictures used in the document are for illustrative purposes only.