

VERTICAL BALER MODEL X50 HD

With a focus on safety and reliability, the X50 HD is designed for users who need a high-quality machine.

- Most material types are compacted easily
- Impressive compression ratio
- Very little expansion of material between press cycles
- Tie off finished bales with either steel wire or plastic strapping
- Fast press cycle (28 secs)
- Electrical control panel safe and easy to access
- All moving parts located inside machine



FEATURES

EFFICIENT COMPACTION

The X50 HD baler compacts heavy-duty materials quickly and efficiently. Easily bale aluminum and tin cans, hard plastic (PET), soft expandable plastic, and paper.

PRODUCE HEAVY BALES

High-capacity machine that produces heavy bales of up to 1,200 lbs. It has a long lifetime due to the unique design and reliable hydraulics.

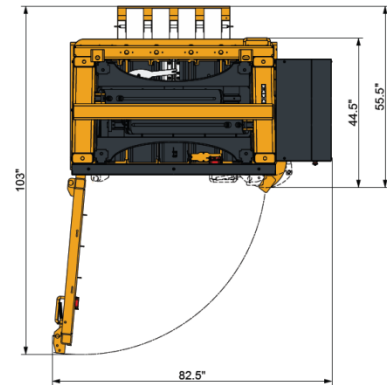
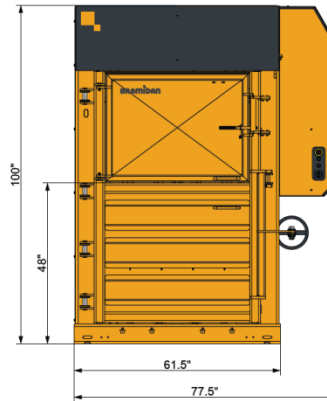

SPECIFICATIONS

Bale Weight Cardboard (lbs): 750-1,000

Bale Weight Plastic Foil (lbs): 850-1,200

Bale Size WxDxH (inches): 48 x 30 x 48

Power Supply: 208/230/480V 3 Phase 60 Hz

Motor (HP): 7.5

Noise Level (dB): 62-64

Cycle Time Average (seconds): 18

Press Force: 110,000 lbs

Dimensions WxDxH (inches): 78 x 86 x 100

Machine Weight (lbs): 5,370

Feed Opening WxH (inches): 43 x 24

Full Bale Light: Yes

Bale Eject: Automatic

Stroke (inches): 48

Number of Ties: 4

Type of Tying: Twine/Steel

Due to continual product improvement Compactors Inc. reserves the right to change specifications without notice. The information and pictures used in the document are for illustrative purposes only.

VERTICAL BALER MODEL X50 HD

OPTIONAL

TIE YOUR BALES WITH STRAPPING OR STEEL WIRES

We offer strapping and steel wires for your balers. Contact us and let us guide you to the right choice for your machine and waste material.



FLAP DOOR FOR BALER LETS YOU HANDLE BOTTLES AND CANS EASILY

Avoid waste back-run when the door is opened. A flap door works like a chute and is suitable for cans and PET bottles.



MAKE YOUR BALER RESISTANT AGAINST LIQUIDS

Prolong machine surface life with a galvanization. Suitable for applications in severe or wet environments or for handling waste with residual liquids.



Due to continual product improvement Compactors Inc. reserves the right to change specifications without notice. The information and pictures used in the document are for illustrative purposes only.