

## VERTICAL BALER

### MODEL V3016HD LIQUID EXTRACTION BALER

Our Liquid Container Baler combines draining and baling refuse beverage or liquid containers in one step. You can increase your recycling time of refuse containers over 7 times faster than manually extracting the liquids. This equipment can make a single bale from up to 4000 aluminum beverage cans and up to 2000 plastic beverage bottles. The baler includes a system to capture the liquid waste and divert it to an approved drain.

**Ideal For:** • Grocery Stores • Home Retailers • Pharmacies • Big Box Retailers • National Accounts • Commissaries • Warehouses • Distribution Centers • Hospitals, Schools & Universities • Recyclers



## PERFORMANCE

- **Nominal Bale Size** 30" x 16" x 24"
- **Bale Weight** Up to 250 lbs
- **Bale Volume** 6.7 cu. ft.
- **No. of Bale Tie Slots** 4
- **Compact Force lbs** - 62,203
- **Average Cycle Time** 49 Seconds
- **Loading Height** 42"
- **Ejector System** Semi-Automatic

## HYDRAULIC/ELECTRICAL

- **Motor HP** 15
- **Voltage** 3 Phase, 208V, 230V, 480V
- **Full Load Amps** 48A, 42A, 21A
- **Pump GPM** 12
- **Factory Set System Pressure** PSI 2200
- **Cylinder Bore x Stroke** 6" x 48"
- **Hydraulic Reservoir Capacity** 22 gal

## AVAILABLE OPTIONS

- **Oil Heater**
- **Weather Proof Package**

### DIM. (in./mm)

- A. 42/1067
- B. 70/1778
- C. 43/1092
- D. 130/3302
- E. 93/2362

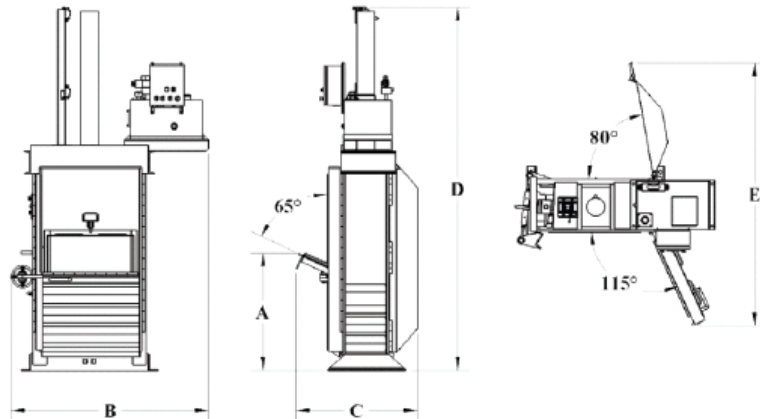

Due to continual product improvement Compactors Inc. reserves the right to change specifications without notice. The information and pictures used in the document are for illustrative purposes only. Compactors Inc. equipment is ETL/CSA certified with UL listed controls and meets or exceeds ANSI standard Z245.5.